



Ranger DX900i S5 SURFACE DRILLS

TECHNICAL SPECIFICATION

Ranger DX900i is a hydraulic, self-propelled, self-contained, crawler based surface drilling rig equipped with a cabin (F.O.P.S. and R.O.P.S.) and rod handling system.

Typical applications for DX900i are road cutting, pipe-line drilling and foundation drilling, as well as production drilling in medium size quarries. Therefore DX900i is most often used by construction contractors, mines and quarries, and also included in the equipment fleet of rental houses as well.

KEY FEATURES

Hole diameter:	89 - 140 mm (3" - 5.5")*
Rock tools:	51 mm or 60mm (2" and 2 3/8")
Rock Drill	27kW
Engine output:	210kW
Flushing air:	9.5 m ³ /min, up to 10 bar
Production capacity:	1,9 Mt/year
Total weight :	19 600 kg

*if larger than 127mm holes drilled please consult factory



HYDRAULIC ROCK DRILL	
Rock drill	RD927L, RD927L-C
Rock tools	45, 51, 60 mm
Operating pressure	100-200 bar
Percussion rate	56
Percussion output power	27kW
Maximum rotation torque	1 750 Nm
Shank lubrication	Air / oil mist
Flushing	Air
Weight	345 kg

FEED	
Feed type	CylF 16 feed, CylF 18 (option)
Total length	7 500 mm, 8 410mm (option)
Rock drill travel	4 680 mm, 5 290mm
Max. length of starter rod	4 875 mm (16'), 5 486 mm (18') (option)
Hole depth with starter rod	4 480 mm, 5 090 mm (option)
Hole depth with second rod	8138 mm
Hose reel	Standard
Feed extension travel	1 300 mm
Feed/pull out force	28 kN
Feed swing	-45°/+45° (-20°/+94°)
Feed tilt	140°
Minimum height for horizontal holes	410 mm

ROD CHANGER	
Rod changer type	RC1712
Storage capacity	7+1 rods (51 mm), 6+1 (60mm, st. feed), 5+1 (60mm long feed)
Rod length	3660, 4267 (12',14')*(Long feed option)
Max. hole depth	30 m,(7x12'+1x16'), 34,3m* (7x14'+1x18') *(option), 25m (60mm)

BOOM	
Boom type	DB5200, articulated
Boom reach	5,2 m
Drilling coverage	55m ² 290°
Collaring height	+2.6 m/-4.5 m
Horizontal holes	To the right

CABIN	
Cabin type	iCab
Certificates	F.O.P.S. and R.O.P.S.
Noise level in the cabin	below 75 dB(A)
Air conditioning	Intelligent air condition safety + *
Pressurization	Standard
Seat	Multiposition
Vibration dampening	Standard
Windows	Safety laminated, tinted, with wipers
Power take-off	12 VDC

* Air condition system contains fluorinated greenhouse gases HFC-134a

POWERPACK	
Engine type	Volvo TAD882VE (EU Stage V)
DEF tank	AdBlue, 45 l
Number of cylinders	6
Engine output	210kW / 1 800 rpm
Transmission type	Gear box
Screw compressor type	Enduro 25
Air filters	2 pcs., with ejector and safety element
Fuel tank	400 l

HYDRAULIC SYSTEM	
Number of gear pumps	2 pcs. for cooling
Number of piston pumps	3 pcs. for drilling, tramming, boom and rodhandling, dust collector
Filtration rate	10 micron abs., return 25 micron, pressure
Cooling capacity	up to +50°C ambient
Hydraulic oil tank	300 l
Shank lubrication device	SLU 22-1 CSL (option)

CONTROL SYSTEM	
Control system type	Sandvik SICA, PLC controlled proportional electro- hydraulics
Tramming/boom/ drilling control	PLC controlled
User interface	Electro-proportional joysticks and touchscreen
Control system diagnostics	Graphical flow chart type
Drilling control system type	iTorque
Antijamming system	For rotation and flushing
Collaring control	Automatic
Preset drilling parameters	Adjustable for fine tuning for different rock conditions
Voltage	24 VDC

DUST COLLECTOR	
Dust collector type	DC 900H
Capacity/vacuum	23 m ³ /min at 1 000 mm vacuum H ₂ O
Filter elements/material	15 pcs/fiber
Total filter surface	12 m ²
Primary cyclone	Standard
Movable suction head	Standard

CARRIER	
Track type	FL 6
Grouser plate width	310 mm
Ground contact length	2 750 mm
Ground pressure	1.0 kg/cm ²
Ground clearance	400 mm
Turnable superstructure	CCW180°+CW110°
Oscillation angles	+/- 10°
Tramming force	156 KN
Max. tramming speed	3.2 km/h

STANDARD COMPONENTS

1 pc Rock drill RD927L, hydraulic with SLU system
1 pc CylF 16 feed HR, With hose reel
1 pc Rod handler RC1712 incl. 1 set of jaws
1 pc BoomDB5200, articulated
1 pc Carrier track mounted, Rotating upper structure CW180+CCW110 Degrees
1 pc Power pack diesel driven, hydraulic pumps and on-board compressor with twin pressure control
1 pc Control system iTorque, incl Flushing control automatics, Shutdown of suction for waterholes
1 pc TIMi for vertical holes and depth measuring
1 pc Operator's cabin F.O.P.S. and R.O.P.S. with Intelligent air condition safety +
1 pc Radio, 12V with USB MP3 Bluetooth, without CD
1 pc Dust collection system DC 900 H, hydraulic, Primary separator
1 pc Flushing control automatics
1 pc Shut down of suction in water holes
10 pcs Working lights, Halogen
1 pc Gauge set for accumulator pressure checking
1 pc Alarm signal
1 Set Manuals, paper copy
1 Set Manuals, USB memory
1 pc Alarm beacon
1 pc Service light
SanRemo Mobile, Bluetooth connectivity
EU-safety

THE JAWS FOR DRILL STEELS

DRILL STEEL TYPE	DRILL STEEL DIAMETER	RECOMMENDED HOLE DIAMETER
MF-rods	45 mm 1 ¾"	76 - 89 mm 3" - 3 ½"
MF-rods	51 mm 2"	89 - 127 mm 3 ½" - 5"
MF-rods	60 mm 2 3/8"	92- 140mm 3 5/8" - 5½"

SELECTION OF OPTIONS

Additional tool/bit box below cabin
Alternative seat with 3-point seat belt and air cushioning
H13 Cabin filter, HEPA
Cooler bag in cabin
Radio CD/MP3 Bluetooth, Handsfree, DAB
Reversing camera
Roller blinds for cabin windows
Vacuum cleaner for cabin
Explosion proof cabin window
Heated mirrors
Driller's Notes - MWD Data Collection for TIM3D
Driller's Office planning software (one-year license)
Automatic feed alignment for TIMi
GPS aiming device for TIM and TIMi inclined holes
TIM3D drill navigation system (Trimble)
TIM3D hole navigation system
TIM3D drill navigation system (Leica)
TIMI for inclined holes and hole depth measuring
TIMI for inclined holes with TIM3D readiness
TIMI laser level based depth measuring
TIMI with open interface (Option laser level included)
RockPulse sensor system
Horizontal drilling kit with extra brake, (not with long feed)
Horizontal drilling kit with extra brake, TIM included (not with long feed)
Long safety cage, replaces standard component
Kit for alternative steels, each
Thread greasing
Full cycle one hole automatic drilling
Power extractor
Readyness for Power Extractor
CSL-system for R92x series rock drill, replaces standard component
Biodegradable hydraulic oil, not with CSL
Central lubrication system Sandvik
Electric fuel filling pump
Electric hydraulic oil filling pump
Electric water filling pump
Fast fill connection for engine coolant, hydraulic and engine oils
Fast fill connection for fuel Wiggins
Fire suppression system Sandvik, Eclipse 65L
Guides for grousers, long
Rear bumper
Long feed for 14' rods, CylF 18 HR, not with horizontal drilling
Hydraulic rear ground support
Hydraulic winch with full radio drilling, tramming boom and rod handling
Remote screen interface (Tablet or mobile phone not included)
Full radio remote control for drilling, tramming, boom and rod handling control
Three bar grouser plates
Towing hook
Extra brake for turnable upper structure (included in horizontal drilling)
Led lights, 9 pcs
Led lights 17 pcs. also carrier rear and side option lights
Cold weather package - 25 degrees
Cold-weather package -25degree, incl watertank heater
Readyness for fuel powered heater
Dustmizer requires flap feeder (engine heater option needed below freezing point)
Flap feeder for dust collector
Sampling device
Water injection system
CME Grinder readyness
Grinder, Dynaset
CME mini junior Grinder
Spare radio remote transmitter
Extra manuals, price will be added according to pricing sheet
First service kit for Ranger DXi series
Special tools for RD92x series, field
Special tools for RD92x series, complete
My Sandvik and SanRemo - select level from extra item

COVERAGE AREA AND DIMENSIONS

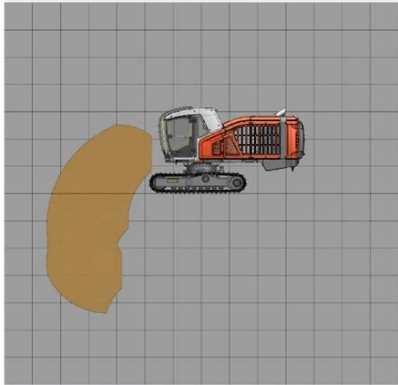

Vertical drilling

1m

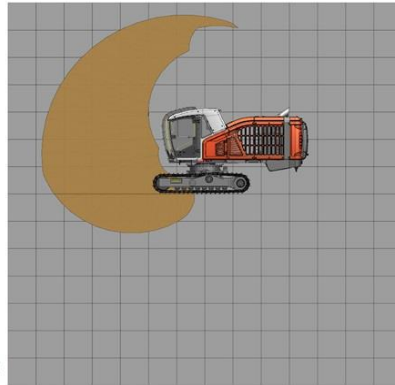

Horizontal drilling

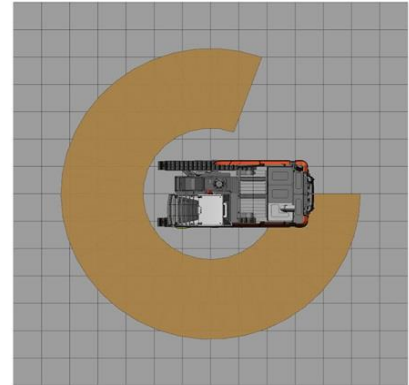

Drilling coverage

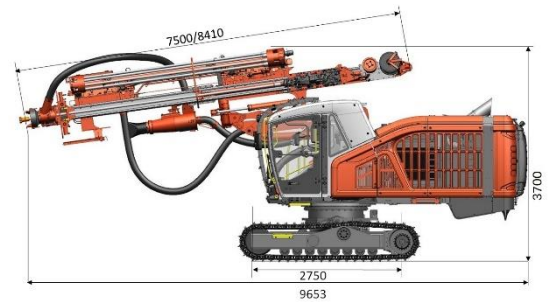

DIMENSIONS

Weight	19 600 kg
Width	2.45 m
Height	3.3 m/4.4 m
With safety cage	3.3 m/4.4 m
With noise silencer	3.7 m/5 m
Total length	12,35m, 13,26m with CylF 18 (option)

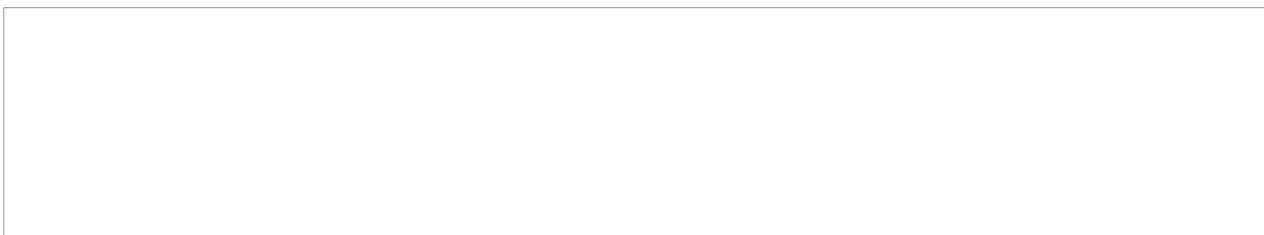

Sandvik Mining and Rock Solutions reserves the right to make changes to the information on this data sheet without prior notification to users. Please contact a Sandvik representative for clarification on specifications and options.

ROCKTECHNOLOGY.SANDVIK