

# BERGMANN II C 804 e

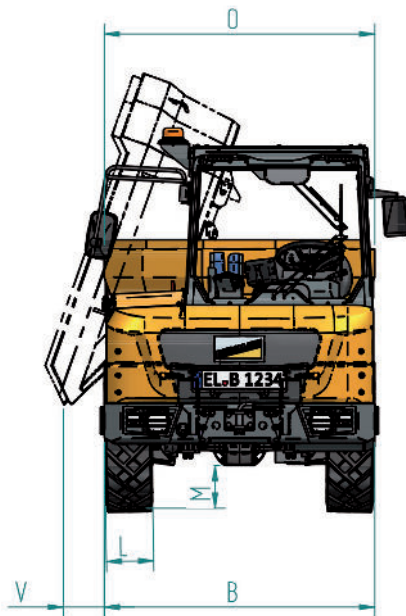

## Swivel-tip dumper

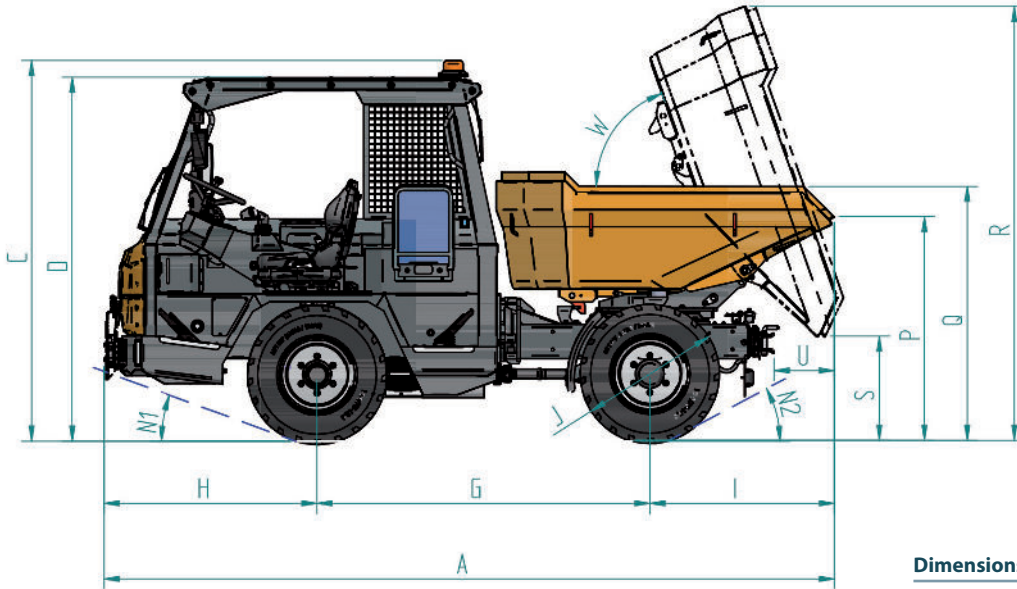

### Dimensions

A	13.32 ft
B	4.92 ft
C	6.95 ft
D	6.64 ft
G	6.07 ft
H	3.88 ft
I	3.37 ft
J	2.54 ft
L	0.86 ft
M	0.78 ft
N1	20°
N2	28°
O	4.92 ft
P	4.08 ft
Q	4.63 ft
R	7.91 ft
S	1.90 ft
U	1.10 ft
V	0.74 ft
W	70°

### Weight

Empty weight	5,620 lb
Payload	6,600 lb

### Bucket capacity

Heaped	1.92 yd <sup>3</sup>
--------	----------------------

All illustrations, dimensions and weights do not necessarily correspond to the standard equipment and are non-binding with regard to tolerance deviations on component level. We reserve the right to make technical changes.

**BERGMANN**  
AMERICAS

## Technical data

### Highlights

- No exhaust emissions and low noise
- Innovative vehicle concept providing the best visibility
- Rotating seat for quick change of direction
- Easy entry and exit
- Low service and operating costs
- Extremely maneuverable with all-wheel steering
- Payload of up to 4 tons

### Engine

Asynchronous engine	
Engine power	33.51 hp
Emission standard	emission free

### Drive Modes

Electric all-wheel drive with automotive control	
Drive stage I	0–6.21 mph
Drive stage II	0–12.43 mph

### Steering

Hydraulic all-wheel steering via priority valve  
Steering types: all-wheel or front-axle steering

### Axles/brakes

- Steered front and rear axles rigidly mounted, front and rear frames connected by means of a swivel joint
- Swivel joint approx. 14° left and right
- Maintenance-free oil bath multi-disk brake with automatic readjustment in the front axle
- Regenerative braking
- Electrically operated parking brake

### Standard tires

All drive wheels 10.0/75–15.3  
Profile type: AS Tractor Profile

### Hydraulics

Asynchronous engine – on-demand	
Engine power	8.04 hp
Hydraulic oil quantity	15 L

### Drive battery

Operating voltage: 80 V  
Lithium iron phosphate battery modules (LFP):  
16 kWh/24 kWh  
BMS monitors with deep discharge protection  
Battery heater for use at low temperatures

### Electrics

- 12 V electrical system for lighting and displays
- Indicator lights for parking brake, direction of travel, etc.
- Battery capacity indicator
- On-board charger (220/240V)

### Standard equipment

- Adjustable hydro swing seat
- Digital dashboard with ignition key
- Rear mounted hitch
- Front and Rear Work lights
- Skip made from wear-resistant fine grain steel
- EC declaration of conformity
- Operating instructions/spare parts list
- Fold down seat behind the driver
- Rotating beacon
- Telematics package
- Rear view camera
- 220/240V Charging Cord

### Optional equipment

- Front mounting bracket (size F3)
- Dual-action hydraulic connections (2x front)
- Bio oil (Panolin) for the hydraulic system
- Ball head locking pin
- Rotating trailer coupling